

Science Olympiad
UT Invitational
October 26, 2024
Astronomy C



Directions:

- Each team will be given **50 minutes** to complete the exam.
- There are four sections: **§A** (General Knowledge), **§B** (JS9), **§C** (DSOs), and **§D** (Astrophysics).
- **Do not write on the exam or image sheet.** Only write on your answer sheet.
- For calculation questions, **work will be graded.** Please show all your work.
- The use of AI tools (e.g. ChatGPT) are expressly forbidden.
- Tiebreakers, in order: §A1–5, §C1, §D1, §C7, §B, §A.
- After the tournament, the exam will be available online at roberty1.com.
- Good luck! And may the stars align for you.

Written by: **The Astronomy A-Team**
Ronit Kapur, ronit.kapur@duke.edu
Benjamin Zhang, benjamin.zhang@columbia.edu
Robert Lee, robertyl@purdue.edu

Section A: General Knowledge

This section consists of multiple choice questions about general astronomy concepts. Each question is worth 2 points, for a total of 60 points.

For the first five (5) questions, consider the H-R Diagram in Image 1.

1. The Sun is located at which point?
2. Towards which point will the Sun evolve to after it leaves the main sequence?
3. A star whose energy source is solely gravitational contraction would be at which point?
4. A red giant would be located at which point?
5. A star at the center of a planetary nebula would be located at which point?

-
6. What type of scale is typically used for the axes of the H-R diagram?

- A. Linear
- B. Quadratic
- C. Semi-logarithmic
- D. Logarithmic

7. Which spectral class of stars has the highest surface temperature?

- A. K
- B. M
- C. G
- D. O

8. What is the characteristic feature of an H II region in terms of its spectral lines?

- A. Continuum emission without lines
- B. Emission lines from ionized hydrogen
- C. Strong absorption lines
- D. Emission of neutral hydrogen

9. What does a negative B-V color index signify about a star's temperature?

- A. The star has an average temperature
- B. The star is relatively hot
- C. The star is pulsating
- D. The star is relatively cool

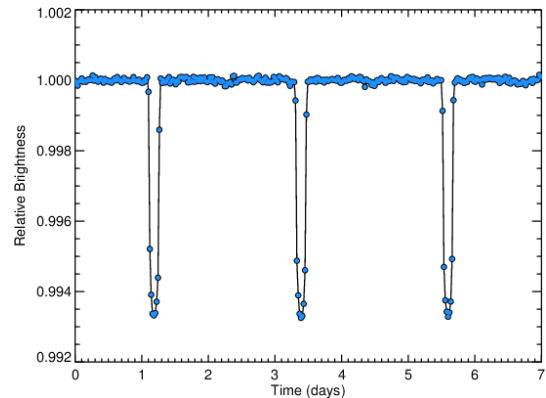

10. What is typically responsible for periodic dips in the brightness of the light curve shown?

- A. Sunspots
- B. Intrinsic opacity fluctuations
- C. Planet orbiting the star
- D. Interstellar gas cloud

11. What feature distinguishes a brown dwarf from a true star?

- A. Brown dwarfs emit strong X-rays
- B. Brown dwarfs are always cooler than M-type stars
- C. Brown dwarfs form from planetary nebulae
- D. Brown dwarfs cannot fuse hydrogen in their cores

12. What spectral feature is commonly associated with molecular clouds?

- A. Rotational transitions of molecules like CO
- B. X-ray emission
- C. H α emission lines
- D. Strong UV absorption

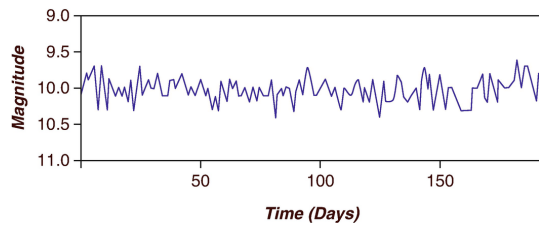

13. What type of star is the above image a light curve of?
- Cepheid
 - Herbig Ae/Be
 - RV Tauri
 - T Tauri
14. Which phenomenon is associated with Herbig-Haro objects?
- Outflows from young stars
 - Spiral arm formation in galaxies
 - Supernova remnants
 - Accretion onto a black hole
15. What is the primary difference between Herbig Ae/Be stars and T Tauri stars?
- T Tauri stars lack circumstellar disks
 - T Tauri stars are older
 - Herbig Ae/Be stars have strong magnetic fields
 - Herbig Ae/Be stars are more massive
16. Which type of star would produce a spectral energy distribution curve with the shortest peak wavelength?
- A blue giant
 - A red dwarf
 - A solar-mass main sequence star
 - A red giant

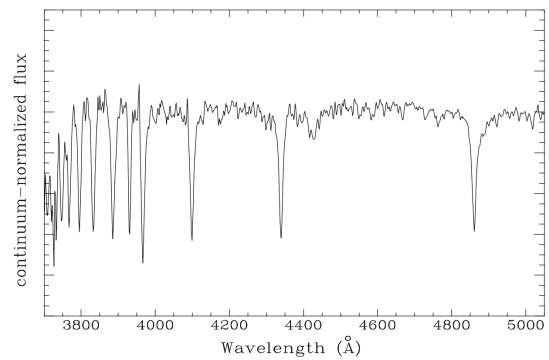

17. What type of star is most likely to produce the spectrum shown above?
- O
 - K
 - G
 - A
18. What is the primary reason that Herbig Ae/Be stars exhibit strong emission lines in their spectra?
- Accretion of material from surrounding gas disks
 - High-energy flares from magnetic fields
 - Large-scale winds from their outer envelopes
 - Shock waves from stellar pulsations
19. Why does the radius of a brown dwarf decrease as its mass increases beyond a certain point?
- Cooling from radiative losses as mass increases
 - Increased radiative pressure from nuclear burning
 - Onset of electron degeneracy pressure
 - Collapse of the brown dwarf into a neutron star

20. Why do sub-Neptune planets often have thick atmospheres despite their smaller sizes compared to Jupiter?
- Their cores are heated by tidal forces from nearby stars
 - Their lower masses allow them to retain hydrogen-rich atmospheres more easily
 - Their formation in cooler regions of protoplanetary disks facilitates gas accretion
 - Their atmospheres are maintained by strong magnetic fields
21. Why are hot Jupiters more easily detectable via radial velocity than Earth-like planets?
- They are located at greater distances from their stars
 - They have higher temperatures, making them more luminous
 - They induce stronger gravitational forces on their host stars
 - They have larger radii and shorter orbital periods
22. What is the primary reason that super-Earths and sub-Neptunes are difficult to distinguish using only the transit method?
- Both types of planets produce similar transit depths
 - Their masses are too small to create significant radial velocity signals
 - Their atmospheric compositions are indistinguishable
 - The orbital periods of these planets overlap significantly
23. How does the amplitude of the radial velocity signal depend on the orbital inclination of the planet relative to our line of sight? Note that an inclination of 0° is face-on and 90° is edge-on.
- It increases to a maximum value as the inclination approaches 0°
 - It increases to infinity as the inclination approaches 0°
 - It increases to a maximum value as the inclination approaches 90°
 - It increases to infinity as the inclination approaches 90°
24. What type of star would make detecting an Earth-sized planet using the radial velocity method most difficult?
- A moderately sized G-type star
 - A large, massive O-type star
 - A low-mass K-dwarf star
 - A small, dim M-dwarf star
25. How would a planet's atmospheric composition influence the depth of its transit as observed from Earth?
- Planets with hazy or high-opacity atmospheres show deeper transits at infrared wavelengths
 - Planets with thick atmospheres would have shallower transits due to scattering effects
 - A planet with a thick atmosphere rich in hydrogen would have deeper transits at optical wavelengths
 - A planet's transit depth is unaffected by its atmospheric composition

26. Many hot gas giants have belts of wind around their equator which distribute heat from the warm dayside to the cool nightside of the planet. This process is most aptly characterized by what fundamental mode of heat transfer?
- Conduction
 - Convection
 - Radiation
 - Advection
27. Image 2 shows a cluster of population I stars. Which of the following is true?
- It is a globular cluster and has a low rate of star formation.
 - It is a globular cluster and has a high rate of star formation.
 - It is an open cluster and has a low rate of star formation.
 - It is an open cluster and has a high rate of star formation.
28. In a globular cluster with a half-mass radius of 10 pc, stars are interacting via gravitational encounters. What happens to the central density and velocity dispersion of the stars if the cluster undergoes core collapse?
- The central density remains constant, but velocity dispersion decreases
 - The central density increases and velocity dispersion decreases
 - The central density increases and velocity dispersion increases
 - The central density decreases and velocity dispersion decreases
29. A molecular cloud is found within a large galaxy, and the local velocity dispersion within the cloud is measured to be 10 km/s. How might the galaxy affect the collapse of the clouds and the formation of stars?
- Tidal forces stretch the clouds, decreasing the Jeans mass and promoting low-mass star formation
 - The external gravitational potential increases the velocity dispersion, leading to a higher Jeans mass and fewer low-mass stars forming
 - The external gravitational potential enhances collapse by compressing the cloud, leading to rapid star formation
 - Tidal forces from the galaxy cluster prevent cloud collapse, lowering the Jeans mass and inhibiting star formation
30. A planetary system forms around a Herbig Ae star, and observations show that the system contains both a sub-Neptune and a super-Earth. How would the planet migration patterns and disk clearing timescales differ between these planets?
- The super-Earth migrates more slowly due to Type I migration, while the sub-Neptune experiences Type II migration and clears a gap
 - Both planets undergo rapid Type II migration, but the sub-Neptune clears a gap faster than the super-Earth
 - The sub-Neptune migrates more rapidly due to its higher mass, while the super-Earth clears a gap more quickly
 - The sub-Neptune undergoes slower Type II migration, while the super-Earth migrates rapidly due to lower mass

Section B: JS9

This section consists of a lab using the JS9 imaging software. Points are shown for each question, for a total of 18 points.

Setup Instructions

- Go to `chandra.cfa.harvard.edu/js9`
- Select the button on the right with the text [The Unofficial Chandra Archive Search Page]. A pop-up should appear.
- In the [Object Name] box, enter “DS Tucanae” and select [Search].

1. [1 pt] How many results appear?

In the table of observations (you may need to scroll down in the pop-up window), find the row with `ObsID 25103` and the column labeled `Title`. To load the data, drag and drop the link there onto the JS9 window.

To adequately see the object, make sure that [Scale > log] is selected; you may also need to adjust the contrast and bias by holding down left click in the JS9 window and moving up/down and left/right, respectively.

At this point, you should be able to see the visual binary star. This is an image of DS Tucanae, a binary star system with a confirmed exoplanet!

2. [2 pts] What date did the observation start?
3. [2 pts] What instrument was used to create this image?
4. [3 pts] What is the angular separation between the two stars in arcseconds?
5. [3 pts] If DS Tucanae is 44.1 parsecs away from Earth, compute its separation in au. Show your work!

Set two circular regions and move one to encompass the primary and the other to encompass the secondary. It will be used for the next two questions.

6. [4 pts] On each star, run a light curve with [Analysis > Light Curve]. (Be sure to use the light curve routine listed under “Server-side Analysis”.) Briefly (1-2 sentences) describe the results.
7. [3 pts] For each star, is there a noticeable change in their brightness, and if so, by what percent does it change? (Round to the nearest 10%.)

Section C: Deep-Sky Objects

This section consists of short free-response questions about this year's deep-sky objects. Points are shown for each sub-question, for a total of 55 points.

1. The cover image shows a composite image of a region of star formation.
 - (a) [1.5 pts] What is the name of this object?
 - (b) [2 pts] This composite image displays two different wavelengths. Identify them.
 - (c) [2 pts] Which telescope collected the longer wavelength data?
 - (d) [2 pts] What types of objects, typically shrouded in dust, are revealed when observing in this wavelength?
2. Located in Virgo, this stellar remnant was found to have a planetary system.
 - (a) [1.5 pts] Name this object.
 - (b) [2 pts] What type of object is it?
 - (c) [2 pts] How many planet(s) have been discovered in this system?
 - (d) [3 pts] Briefly (1-2 sentences) describe how the planets were discovered: (i) what type of data was collected, (ii) what telescope collected it, and (iii) how the planets affected the data.
3. Image 3 is a plot of exoplanet related data.
 - (a) [2 pts] What exoplanet detection method is shown by the plot?
 - (b) [3 pts] Do you expect this exoplanet to have a circular or elliptical orbit? Explain your answer.
 - (c) [2 pts] To three significant figures, what is the eccentricity of the exoplanet's orbit?
4. Images 4 and 5 show the temperature maps of WASP-121b, using a Mollweide projection, at pressures 5×10^3 Pa and 10^5 Pa, respectively.
 - (a) [2 pts] Which image corresponds to a temperature map at a higher altitude? Explain your answer.
 - (b) [2 pts] The temperature maps, particularly Image 5, suggest the existence of what type of phenomenon?
 - (c) [3 pts] Considering your answer to part (a), explain why the patterns in the temperature maps differ.

Questions 5–7 are on the following page.

5. LTT 9779b is an exoplanet discovered in 2020.
- [3 pts] If the Moon orbits Earth at a distance of 3.85×10^8 m, how many times further does LTT 9779b orbit from its host star? Give your answer to the nearest whole number.
 - [2 pts] Image 6 shows all currently confirmed exoplanets and their method of discovery plotted against mass, radius, and orbital period. Why did the authors only include the “doppler” exoplanets in the upper plot?
 - [2 pts] The same image shows LTT 9779b sitting in a region devoid of other exoplanets. What is this region known as?
 - [3 pts] What is the prevailing theory for the lack of exoplanets in this region?
6. WASP-17b was the first exoplanet discovered to have a retrograde orbit.
- [3 pts] This discovery was surprising because it was not predicted by planetary formation theory. Briefly (1-2 sentences) explain why astronomers expect planets to orbit in the same direction and their star’s spin.
 - [3 pts] The sky-projected angle between the rotation axis of WASP-17 and the orbital axis of WASP-17b was measured to be around 150° . Draw a diagram showing this angle. Clearly denote the rotation and orbital axes by following the right-hand rule.
(*Hint: Draw the orbit of the exoplanet edge-on.*)
 - [2 pts] What phenomenon was used to find this angle?
7. Almost all of the objects in this year’s deep-sky object list are related to exoplanets.
- [3 pts] Identify the objects that satisfy at least one of the following conditions:
 - If the object is an exoplanet, it was first detected by transit.
 - If the object is a host star, at least one of its planets was first detected by transit.You may instead identify the complement: all objects not satisfying any of the conditions. If you do so, start your answer with “NOT: ”.
 - [2 pts] From the objects not satisfying any of the conditions, find the median distance in parsecs.
(*Hint: There are an odd number of these objects.*)
 - [2 pts] Image 7 displays what exoplanet detection method?

Section D: Astrophysics

This section consists of calculations and a few derivations. Points are shown for each sub-question, for a total of 37 points. Numerical answers must be provided to 3 significant figures. Please show your work: no work, no points. Partial credit may be awarded for correct work.

- 1. A Sumerian King.** You have been studying the main sequence star Gilgamesh, which you have determined is 2.5 parsecs away.

 - [3 pts] If you are observing Gilgamesh's motion for a 1-year period, what is its maximum angular displacement in the sky?
 - [3 pts] If Gilgamesh has an apparent bolometric magnitude of 2.5, what is its absolute magnitude?
 - [3 pts] What is the luminosity of Gilgamesh in solar luminosities?
 - [3 pts] If Gilgamesh has a radius of 0.76 solar radii, what is its effective temperature in Kelvin? (If you were unable to answer part (c), you may substitute it with a value of $0.7L_{\odot}$.)
 - [3 pts] The black-body radiation curve emitted by Gilgamesh peaks at what wavelength in nm? (If you were unable to answer part (d), you may substitute it with a value of 4160 K.)
 - [4 pts] You discover that Gilgamesh has an exoplanet, Enkidu! If Enkidu has an albedo of 0.4 and is orbiting at a distance of 1.4 au, what is the effective surface temperature of Enkidu in Kelvin? Is it in the habitable zone? (You may substitute the effective temperature of Gilgamesh with 4160 K.)
- 2. Exoplanet Detection!** Let's take a closer look at the two most common exoplanet detection methods. Transit detection has confirmed over 4,000 exoplanets so far. For close to edge-on orbits ($i \sim 90^\circ$), as a planet orbits its host star, it will cause a dip in the observed stellar flux as it transits in front of the star.

For the following questions, assume a circular orbit. The diagram below shows a transiting exoplanet and the system's associated light curve. R_s and R_p are the radii of the star and planet, respectively. For an edge-on orbit, the planet transits along the equator of the host star. For i near 90° , it transits along a chord a distance bR_s away from the star's center, where $0 \leq b \leq 1$ is a constant termed the *impact parameter*.

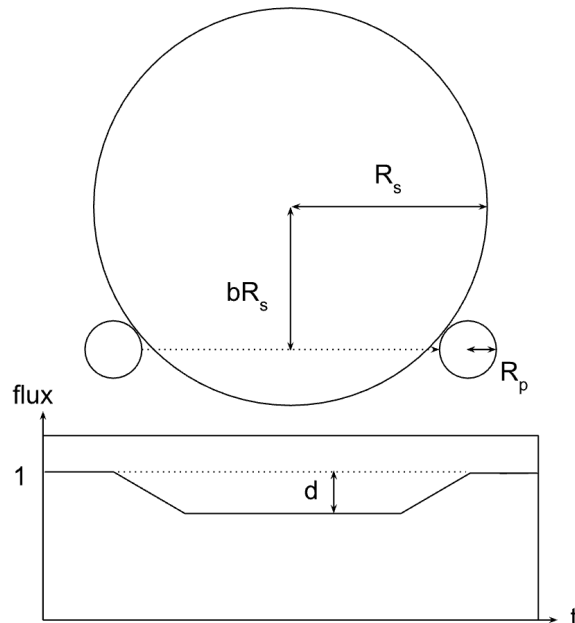

- (a) [4 pts] What is the maximum and minimum inclination for the transit to be visible? Express your answer in terms of the parameters in the image above and the semi-major axis of the orbit, a .
- (b) [3 pts] What is the maximum possible dip in flux observed, d , as a fraction of the total stellar flux? Express your answer in terms of R_p and R_s .

Another popular form of exoplanet detection is the radial velocity method, which utilizes the Doppler “wobble” emerging from the gravitational force exerted on the host star. This Doppler shift can be measured to create a radial velocity curve of the host star over time. A radial velocity curve is shown below with a maximum observed speed of v_{\max} and period T . For the following questions, assume the planet’s motion follows an edge-on, circular orbit.

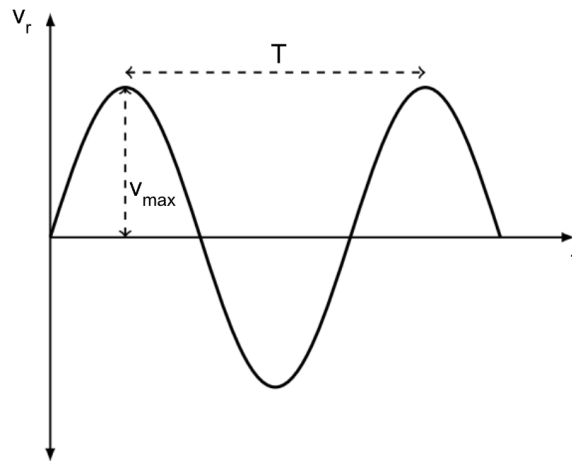

- (c) [4 pts] Suppose that we have been able to determine the mass of the host star M_s . What is the orbital speed of the planet v_p ? Give your answer in terms of observed quantities from the radial velocity curve (T , v_{\max}), as well as fundamental constants.
- (d) [4 pts] What is the mass of the planet, M_p , in terms of the host star mass M_s , its radial velocity amplitude v_{\max} , and the inferred planet speed v_p ?
- (e) [3 pts] How does your expression for M_p change when the orbit cannot be assumed to be edge-on ($i \neq 90^\circ$)?

Science Olympiad

UT Invitational

October 26, 2024

Astronomy C Image Sheet



Directions:

- Do not open until the test begins.

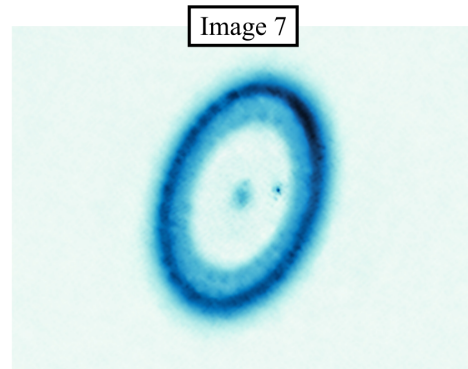
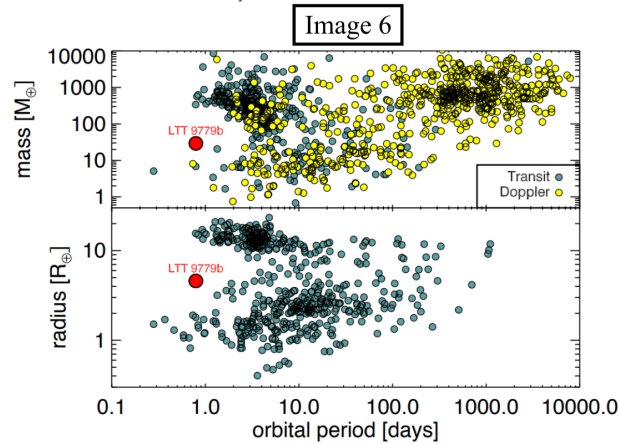
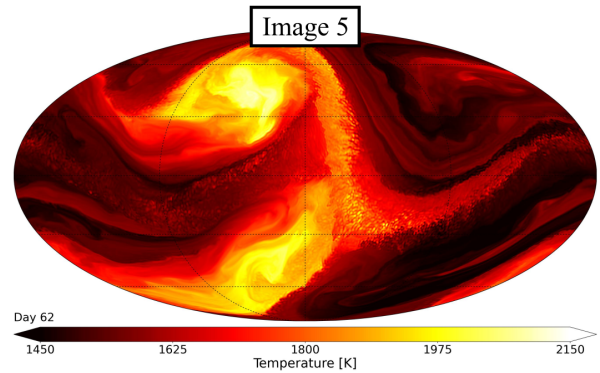
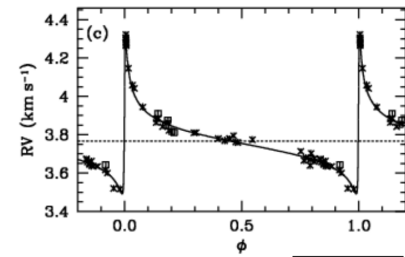
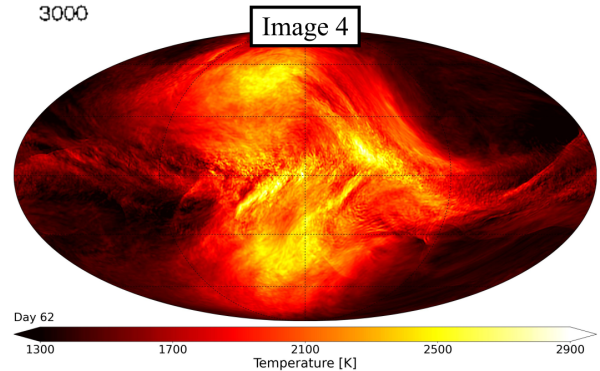
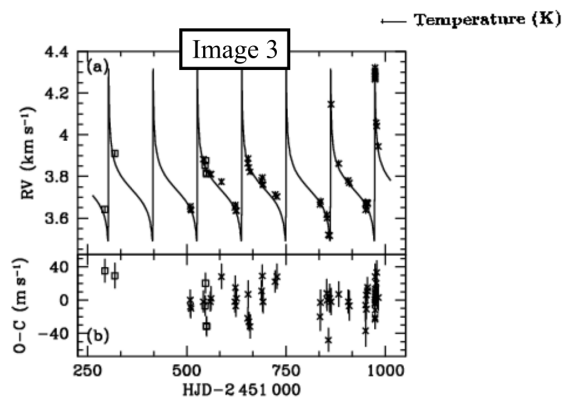
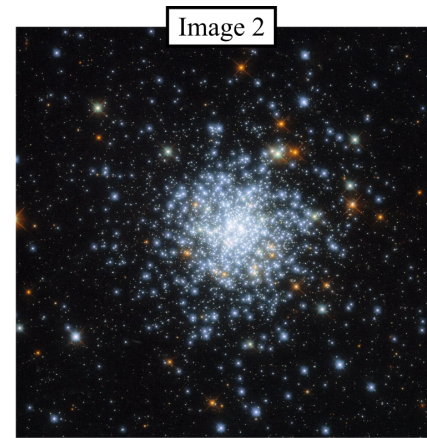
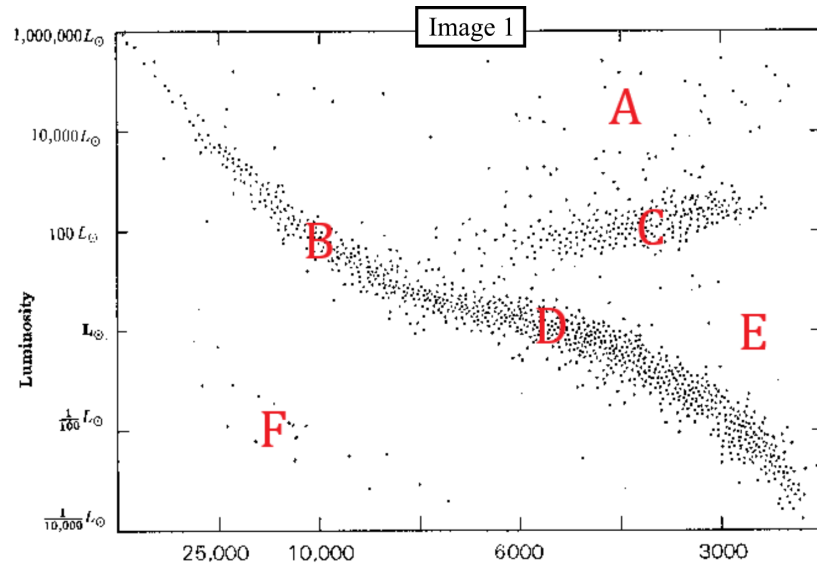

Science Olympiad

UT Invitational

October 26, 2024

Astronomy C Answer Sheet



Team Name and Number: _____

Participant Name(s): _____

Total Score: ____ / 170

Rank: ____

Directions:

- Read the directions on the test cover.

Section A (60 points)

- 1. _____
 - 2. _____
 - 3. _____
 - 4. _____
 - 5. _____
 - 6. _____
 - 7. _____
 - 8. _____
 - 9. _____
 - 10. _____
 - 11. _____
 - 12. _____
 - 13. _____
 - 14. _____
 - 15. _____
 - 16. _____
 - 17. _____
 - 18. _____
 - 19. _____
 - 20. _____
 - 21. _____
 - 22. _____
 - 23. _____
 - 24. _____
 - 25. _____
 - 26. _____
 - 27. _____
 - 28. _____
 - 29. _____
 - 30. _____
-

Section B (18 points)

- 1. _____
 - 2. _____
 - 3. _____
 - 4. _____
 - 5.
 - 6. _____
 - 7. _____
-

Section C (55 points)

1. (a) _____

(b) _____

(c) _____

(d) _____

2. (a) _____

(b) _____

(c) _____

(d) _____

3. (a) _____

(b) _____

(c) _____

4. (a) _____

(b) _____

(c) _____

Team Name:

Astronomy C - UT 2024

Team Number:

5. (a) _____

(b) _____

(c) _____

(d) _____

6. (a) _____

(b) 

(c) _____

7. (a) _____

(b) _____

(c) _____

Section D (37 points)

1. (a)

(b)

(c)

(d)

(e)

(f)

2. (a)

(b)

(c)

(d)

(e)

Science Olympiad

UT Invitational

October 26, 2024

Astronomy C Answer Key



ANSWER KEY ANSWER KEY
ANSWER KEY ANSWER KEY
ANSWER KEY ANSWER KEY
ANSWER KEY ANSWER KEY
ANSWER KEY ANSWER KEY
ANSWER KEY ANSWER KEY
ANSWER KEY ANSWER KEY
ANSWER KEY ANSWER KEY

Section A (60 points)

1. D 2. C 3. E 4. C 5. F
6. D 7. D 8. B 9. B 10. C
11. D 12. A 13. D 14. A 15. D
16. A 17. D 18. A 19. C 20. C
21. C 22. A 23. C 24. B 25. A
26. D 27. D 28. C 29. B 30. A
-

Section B (18 points)

1. [1 pt] 4
2. [2 pts] 2022-02-20. Half credit for 2022-02-21.
3. [2 pts] ACIS
4. [3 pts] 5" (Accept 4-6")
5. [3 pts] 220.5 au (Accept 176-265 au)
6. [4 pts] Upper star (secondary): At a constant brightness of ~ 15 counts/sec with no noticeable change.
Lower star (primary): At a constant brightness of ~ 40 counts/sec until $t \approx 761\,794\,200$ s, where it increases to ~ 60 counts/sec.
Half credit for any other qualitative or quantitative description that suggests the light curve was correctly generated.
7. [3 pts] The primary has a 50% (Accept 40-70%) increase in brightness.

Section C (55 points)

1. (a) [1.5 pts] 30 Doradus or Tarantula Nebula
(b) [2 pts] X-ray and infrared (**1 each**)
(c) [2 pts] JWST
(d) [2 pts] Protostars
2. (a) [1.5 pts] PSR B1257+12
(b) [2 pts] (Millisecond) pulsar
(c) [2 pts] 3
(d) [3 pts] The Arecibo (**1**) telescope measured the time of arrivals (TOAs) of the pulsar pulses (**1**). Gravitational perturbations (**1**) from the orbiting planets caused the TOA to vary sinusoidally.
3. (a) [2 pts] Radial-velocity or doppler spectroscopy
(b) [3 pts] It's in an elliptical orbit (**1**). If it was in a circular orbit, it would exhibit a sinusoidal radial-velocity curve, which is not the case. Any justification based on the shape of the curve (**2**).
(c) [2 pts] Accept 0.923 to 0.934
4. (a) [2 pts] Image 4 (**0.5**) because pressure decreases with altitude (**1.5**) and it has lower pressure.
(b) [2 pts] Weather patterns with storms and fronts
(c) [3 pts] The dayside-nightside temperature gradient is more strongly maintained (**1.5**) since Image 4 is at a higher altitude and the thermal time scale is shorter (**1.5**).
5. (a) [3 pts] Accept 6 or 7
(b) [2 pts] Can't determine the radius of exoplanets detected only by the radial-velocity method
(c) [2 pts] (Hot) Neptune desert
(d) [3 pts] Exoplanets so close to their host star would either have enough mass to remain Jupiter-sized or their primordial atmosphere would be completely eroded.
(1) for *only* mentioning the exoplanet is close or hot.
6. (a) [3 pts] Planets form from protoplanetary disks (**1**), which spin in the same direction (**1**) as their star. So, we'd expect objects formed from them to have the same behavior (**1**).
(b) [3 pts] Horizontal line showing the orbit of WASP-17b (**1**) with its direction or orbital axis. WASP-17 placed at the center of the orbit with a spin direction 150° clockwise or counterclockwise from the orbital axis (**2**).
(c) [2 pts] Rossiter-McLaughlin effect
7. (a) [3 pts] HD 80606, WASP-17b, WASP-121b, LTT 9779b, GJ 1214 b, K2-18b, TOI-270d, LHS 3844b, WD 1856+534, Kepler-62, AU Microscopii (**1 for 8–11; 2 for 12–14; 3 for 15–16 correct**)
(or NOT: Orion Nebula, 30 Doradus, PSR B1257+12, 55 Cancri, Epsilon Eridani)
(b) [2 pts] (Orion Nebula) 412 pc (Accept 390–450 pc)
(c) [2 pts] Direct imaging

Section D (37 points)

Award up to half credit for correct work with incorrect answer

1. (a) [3 pts] 0.8'' (Exact). *Only (1) for 0.4''.*
- (b) [3 pts] 5.51 (Exact)
- (c) [3 pts] 0.492 L_{\odot} (Accept 0.48–0.55 L_{\odot})
- (d) [3 pts] 5550 K (Accept 5450–5700 K). If using $L = 0.7 L_{\odot}$, 6060 K (Accept 6010–6110 K)
- (e) [3 pts] 521 nm (Accept 510–530 nm). If using $T = 4160$ K, 697 nm (Accept 690–710 nm)
- (f) [4 pts] 173 K (Accept 168–178 K). If using $T = 4160$ K, 130 K (Accept 125–135 K) **(3)**
 Since this is below the freezing point of water, is not in the habitable zone **(1)**.

2. (a) [4 pts] $a \cos(i) = bR_s$. Since $0 \leq b \leq 1$, $i \geq \cos^{-1}(R_s/a)$. ($i \geq \cos^{-1}((R_s + R_p)/a)$ also accepted)

- (b) [3 pts] $d = (R_p/R_s)^2$. *Only (1) for $d = (R_s^2 - R_p^2)/(R_s^2)$.*

- (c) [4 pts] From Kepler's third law, $a^3 = \frac{GM_s T^2}{4\pi^2}$ **(1)**.

Substituting into the circular orbit velocity formula $v_p = \sqrt{\frac{GM_s}{a}}$ **(1)**, we get $v_p = (2\pi GM_s/T)^{1/3}$ **(2)**.

- (d) [4 pts] Because the planet and host star orbit around their center of mass, $M_p v_p = M_s v_s$, where v_s is the true velocity of the star, which equals v_{\max} in the case of an edge-on orbit. So we can write:

$$M_p = \frac{M_s v_{\max}}{v_p}.$$

Only (3) for $M_p = (M_s v_s)/v_p$.

- (e) [3 pts] If the orbit is not edge-on, $v_{\max} = v_s \sin(i)$, as v_{\max} is the radial component of the star's true velocity. So we get:

$$M_p = \frac{M_s v_{\max}}{v_p \sin(i)}.$$